

(No Model.)

2 Sheets—Sheet 1.

R. H. WATSON.

Machine for Framing Timber.

No. 232,575.

Patented Sept. 21, 1880.

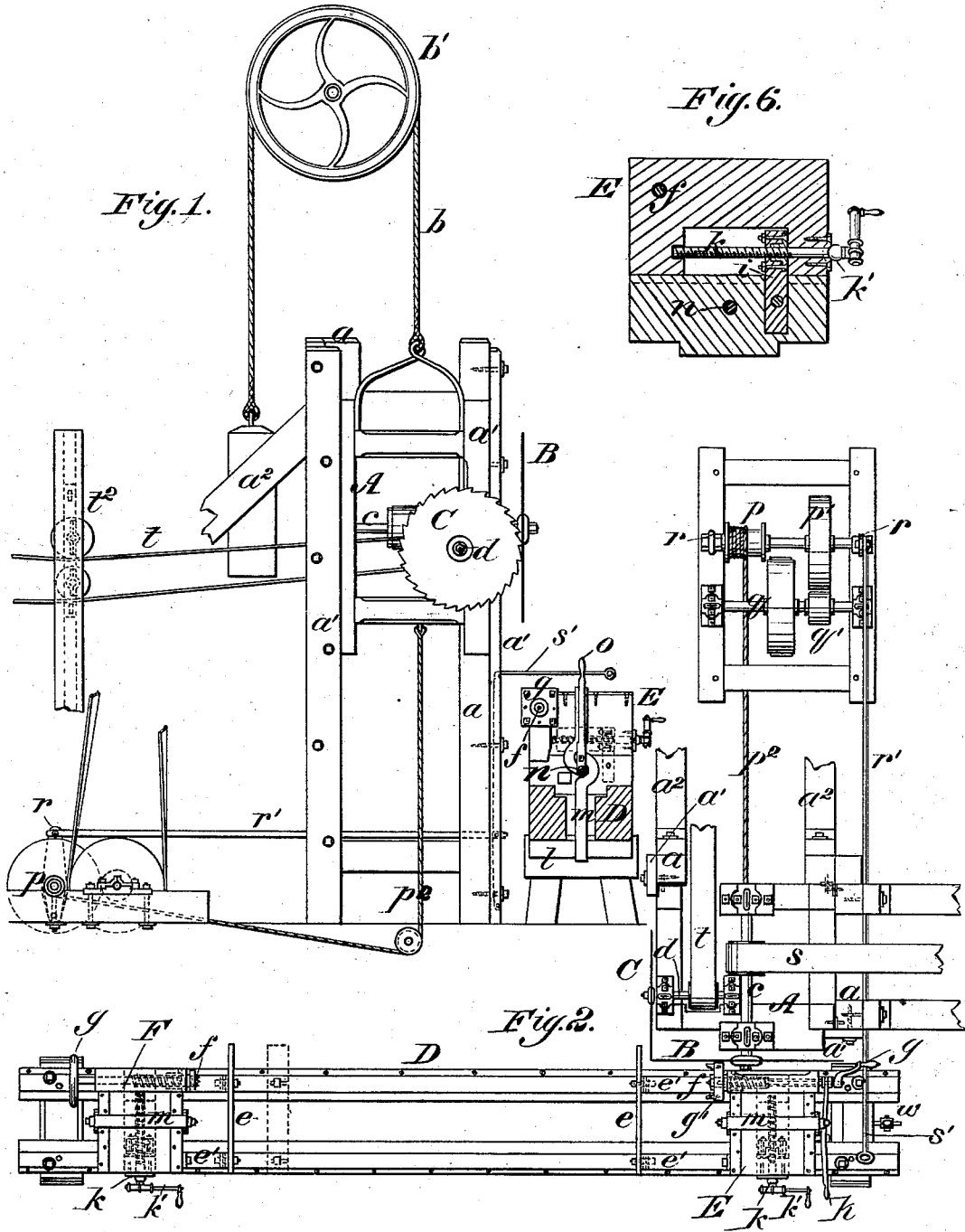

WITNESSES:

Donn S. Twitchell
C. Sedgwick

INVENTOR:

R. H. Watson
BY *Miner Ho*
ATTORNEYS.

R. H. WATSON.

Machine for Framing Timber.

No. 232,575.

Patented Sept. 21, 1880.

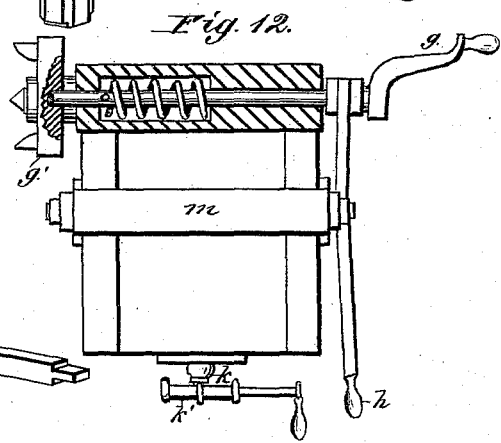
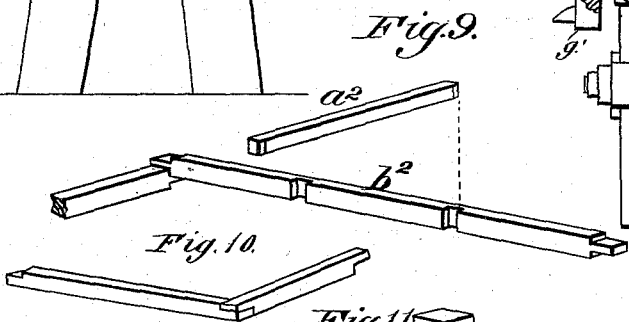
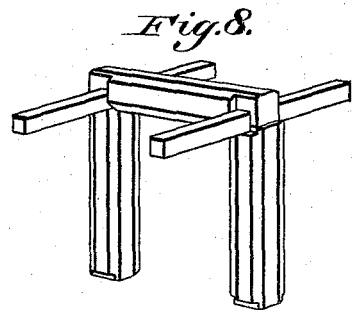
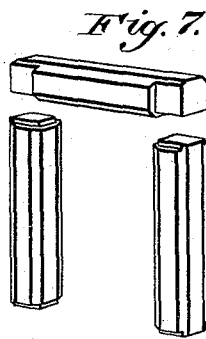
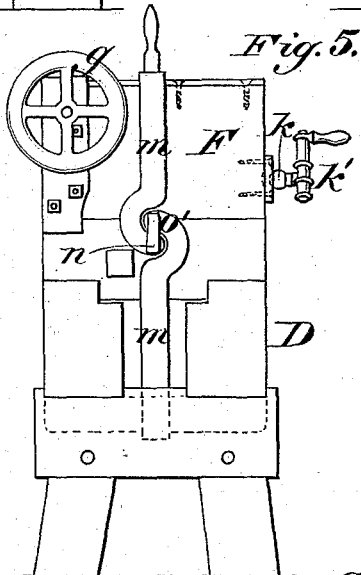
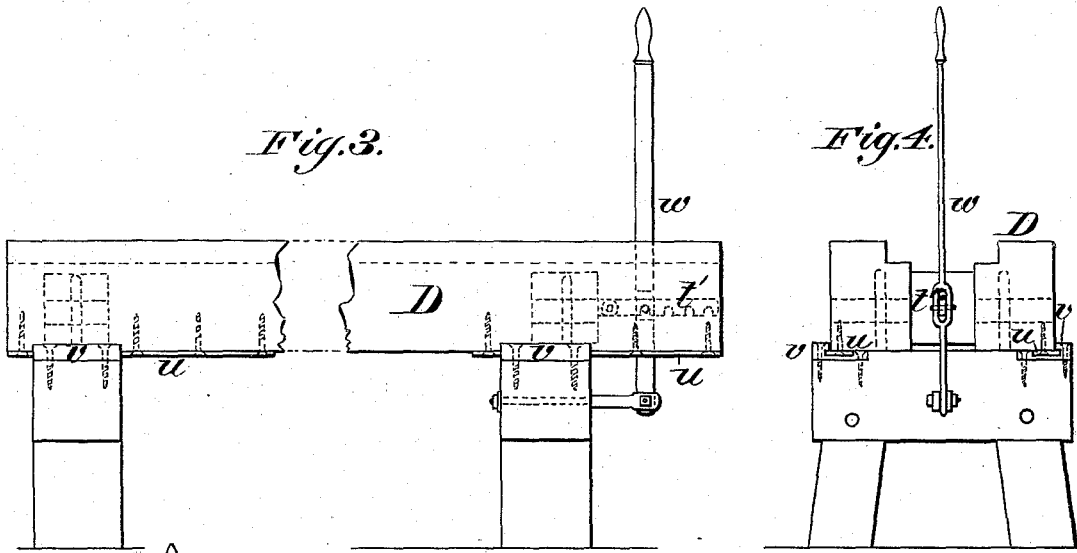

WITNESSES:
Donn S. Twitchell
C. Sedgwick

INVENTOR:
R. H. Watson
 BY *Munn & Co*
 ATTORNEYS.

UNITED STATES PATENT OFFICE.

RICHARD H. WATSON, OF LEADVILLE, COLORADO.

MACHINE FOR FRAMING TIMBER.

SPECIFICATION forming part of Letters Patent No. 232,575, dated September 21, 1880.

Application filed May 26, 1880. (No model.)

To all whom it may concern:

Be it known that I, RICHARD H. WATSON, of Leadville, in the county of Lake and State of Colorado, have invented new and useful
5 Improvements in Machines for Framing Timber, of which the following is a specification.

This machine is intended to accomplish by
10 power the work of framing timber used in mines, shafts, tunnels, and similar underground works. I make use of a suspended carriage or frame fitted for movement in vertical guides and carrying two horizontal saw-
15 arbors fitted at right angles. This is combined with a bed carrying adjustable head and tail blocks for holding the timber and presenting it properly to the saws. I use a winding-
20 drum and friction-pulleys for feeding the saws and devices of novel character for centering and clamping the timber.

The construction and operation will be particularly described hereinafter with reference to the accompanying drawings, and the invention pointed out in the claims.

In the drawings, Figure 1 is a side elevation
25 of the machine. Fig. 2 is a plan view. Fig. 3 is a side view of the fixed bed. Fig. 4 is an end view of the bed at the upper end. Fig. 5 is an end view of the bed and tail-block. Fig. 6 is a sectional side view of the head-block.
30 Figs. 7 to 11 are perspective views, representing timbers as cut by the machine. Fig. 12 is a view showing perforated disk and stop-pin.

Similar letters of reference indicate corresponding parts.

35 A is the suspended carriage, consisting of a rectangular frame of vertical corner-posts and cross-girths, confined between vertical standards *a*, that are fitted with cap-plates *a'* to form guides for the carriage. The standards *a* are
40 stiffened by braces *a''*, and the carriage A is suspended by a rope, *b*, that passes over a sheave, *b'*, and carries a weight sufficient to balance the carriage and its attached parts.

Horizontally across the cage extends the arbor *c* of a circular ripping-saw, B, the same
45 being supported by boxes that are fixed on opposite center-girths of the carriage, so that the saw works upon the outside of and parallel with one side or face of the case. At right
50 angles to the arbor *c*, and above or below the same, is fitted the arbor *d* of a circular cut-off

saw, C, the boxes of arbor *d* being also fixed upon center-girths of the carriage, so that the saw C is outside and parallel to one face of the carriage. The cutting-edges of the saws
55 B C are thus made to work to the same vertical line, with the center of one saw slightly above that of the other.

At the front of the carriage A, and parallel with the plane of the rip-saw B, is a fixed bed-
60 frame, D, which is generally similar to a lathe-bed, and supports the head-block E and tail-block F. Upon the bed D are fitted cross-bars *e*, which are adjustable, and serve as rests for the timber.
65

The blocks E F are fitted with centers *f*, adjustable lengthwise by screw-rods, which may be turned by the handles *g g*. The center *f* of the head-block is fitted with a disk, *g'*, which is loose so that it may revolve, and which is
70 formed on its face with spurs for entering the timber. In the disk *g'*, near its edge, there are holes for receiving the end of a pin that extends through the head-block and has its rear end connected to a lever, *h*. The pin is
75 thrown inward by a spring to enter the holes of disk *g'*, and thereby prevent the timber from turning, and may be withdrawn by the lever *h* when it is desired to turn the timber on the
80 centers.

The center *f* of the tail-block is both a hollow and point center. At the back of its face is fitted a collar, and back of the collar for a few inches the stem is screw-threaded, and engages with a nut set in the tail-block, so that
85 by the hand-wheel *g* the center may be forced into the timber.

The blocks E F are formed of an upper and lower portion, tongued and grooved together,
90 (see Fig. 6,) so that the upper section of each block may be moved transversely of the bed D. In the under side of the upper block is formed a chamber. (Shown in Figs. 1 and 6.) In this chamber a stud, *i*, from the lower section projects, and to the upper end of this
95 stud is fixed the nut of a screw, *k*, of which *k'* is the handle. This screw is made fast to the upper section by a collar, so that by turning the handle of the screw the upper section of the block carrying the center will be moved
100 to adjust the timber to and from the carriage A.

For clamping the head-blocks to the bed I

make use of a cross-bar, *l*, Fig. 1, suspended from each block by a strap or band, *m*, which passes over the block and beneath the bar. This strap is divided on opposite sides of the block. The end of the upper portion at each side is connected to a cross-shaft, *n*, fitted in the block, while the ends of the lower sections are connected at one side to a lever, *o*, at the other side to a link, *o'*, which lever and link are fixed on the opposite ends of shaft *n*. By turning the lever *o* the ends of the strap *m* will be brought together or separated to tighten or loosen the band, as required. This construction permits the blocks to be firmly secured and quickly loosened.

The timber-rests *e* are fitted on bed D in front of the head and tail blocks, as shown in Fig. 2. These rests are carried by plates *e'*, which at one end are bolted to the blocks E F, and at the outer end are fitted with jointed flaps, to which the bars *e* are attached. The bars *e* are to be turned up for supporting the timber while it is being centered and turned down flat, as shown by dotted lines, while it is being framed. The bars *e* are fitted adjustably on the flaps of plates *e'*, for regulating the position at which the timber will be supported.

For bringing the saws down to the bed I make use of a winding-drum, *p*, mounted on a suitable fixed frame at the back of the carriage-guides *a*, from which drum a rope, *p'*, passes around a sheave to the bottom of the carriage A, where the end is attached. The shaft of the drum *p* is carried by bearings fitted in arms *r*, one of which is pivoted in the frame, and upon said shaft is fixed a friction-wheel, *p'*. In the frame is fitted a shaft, *q*, carrying a pulley for connection to power, and also carrying a friction-wheel, *q'*. From the pivoted arm *r* a rod, *r'*, extends to and is connected with a hand-lever, *s'*, which is, for convenience, hung adjacent to the head-block. By the movement of lever *s'* the friction-wheels *p'* *q'* can be brought together and the winding-drum put in motion.

The saws B C are driven by belts *s t* from shafts which will be fitted horizontally in a position midway of the movement of the carriage. The belts will be fitted with tighteners, such as shown at *t'*, Fig. 1, or of any desired construction.

In many cases the work upon the timber is to be done farther from the end on one side than on the other, thus requiring the timber to be moved lengthwise.

To move the loaded blocks without relieving the fastenings of the timber I make use of devices shown most clearly in Figs. 3 and 4.

The two longitudinal bearers of the bed-frame D are disconnected from the supporting-bents. At the under side of the bed-frame there are attached straps *u*, with their edges slightly projecting. On the upper side of the supporting cross-bars, at each end, are attached iron chairs *v*, which are formed with grooves to receive the projecting edges of the straps *u*.

By this construction the bed-frame is rendered capable of endwise movement, and is prevented from being thrown over sidewise.

Upon the supporting-bent, at the head of the machine, is hung a lever, *w*, which is forked to stride a notched bar, *t'*, that is hung on the end of the bed-frame, and the fork of lever *w* is provided with a cross-pin for engagement with the notches of bar *t'*. This lever *w* is to be used for giving the endwise movement to the bed-frame, and may be caught into either notch of bar *t'*, as required.

The machine is to be operated as follows: The cage being in the raised position, the timber is placed upon the rests *e*. The centers and spurs are then made to enter the timber by means of the hand-wheel on the center of the tail-block. Then, by means of lever *h*, the holding-pin is made to enter one hole of the disk *g'* to prevent revolution of the timber. The friction-feed is then to be applied by means of the hand-lever *s'* to bring the carriage and saws down, and the timber is cut and finished upon that side next to the carriage. On relieving the lever *s'* the carriage will be quickly returned to its upper position by the balance-weight. The holding-pin of the disk *g'* is then to be drawn out, the timber given a quarter-revolution, and again secured for being operated on as before.

This operation is repeated until two, three, or four sides are framed, as desired. If both ends are to be framed, the timber is to be reversed, end for end, and the described operation repeated.

In Fig. 7 I have shown a set of drift-timbers as framed or cut by the machine. Fig. 8 shows these timbers as put together, with the addition of braces to reach from one set to the other along the drift of the mine.

Fig. 9 shows crib-timbers cut for a three-compartment shaft. The timbers *a*² fit the grooves in the long timbers *b*² and form partitions dividing the shaft.

Fig. 10 shows timbers as cut for a single-compartment shaft, and Fig. 11 represents another form of framing-timber adapted for some shafts. This work may be done in either round or square timber.

Having thus described my invention, I claim as new and desire to secure by Letters Patent—

1. In combination with a bed-frame having adjustable head-blocks for carrying the timber, the balanced carriage A, fitted for feed movement in standards *a* by a winding-drum and rope, and provided with revolving saw-arbors driven by belts from separate shafts, all substantially as shown and described.

2. In timber-framing machines, the movable blocks E F, provided with adjustable centers *f*, and fitted for adjustment crosswise of the bed, said blocks having bars *l*, divided straps *m*, shafts *n*, levers *o*, and link *o'*, combined with the bed-frame D, substantially as and for the purposes set forth.

3. In timber-framing machines, the screw-center *f*, loose disk *g*', having spurs and apertures, lever *h*, and holding-pin for the disk, combined together and with the head-blocks E
5 F, having bars *l*, divided straps *m*, shafts *n*, levers *o*, and links *o'*, substantially as and for the purposes specified.

4. The combination of the head-blocks E F, made in two parts and tongued and grooved
10 together, substantially as shown and described, having stud *i*, screw *k*, handle *k'*, with the clamping mechanism *l m n o o'* and the bed-frame D, as set forth.

5. The bars *l*, divided straps *m*, shafts *n*, levers *o*, and links *o'*, combined with the bed- 15 frame D and blocks E F, substantially as shown and described, and for the purposes set forth.

6. In timber-framing machines, the plates *u*, chairs *v*, lever *w*, and slotted bar *t'*, combined with the bed-frame D and its supports, sub- 20 stantially as and for the purposes set forth.

RICHARD H. WATSON.

Witnesses:

RAYMOND WHINNERAH,
JOHN BARKIE.